



KOMPTECH
TECHNOLOGY FOR A BETTER ENVIRONMENT



SIMPLICITY
EQUIPMENT & SERVICE

WIND SIFTER



HURRIKAN HURRIKAN S

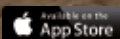

EDITION WITH AUGMENTED REALITY CONTENT

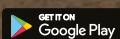

Download the „KompTech LookBeyond!“ app. Scan marked and numbered projects with the „LookBeyond! eye“ to see additional information.



APPLICATION

HURRIKAN IN OPERATION

HIGHLIGHTS

- » High throughput with up to 95 percent separation precision through optimum adjustability for the material
- » The Hurrikan S has an expanded suction area for higher throughput and separation precision.
- » 80 km/h chassis for high mobility and optional onboard diesel generator for operation at any site
- » The mobile machine can be combined with almost any screen

The Hurrikan wind sifters provide effective removal of plastic film from screen overflow. They work with a patented pressure-suction process that gives the Hurrikan S a separation efficiency of up to 95 percent (up to 90 percent for the Hurrikan). Magnetic and roller separators can further enhance the quality of the recyclable output.

The Hurrikan is offered as a centre axle trailer (tandem axle for the S version). Electric drive of all components ensures top efficiency while offering many control possibilities. An optional generator provides full independence from grid power.

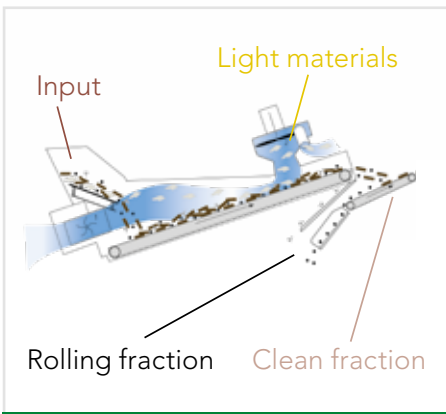
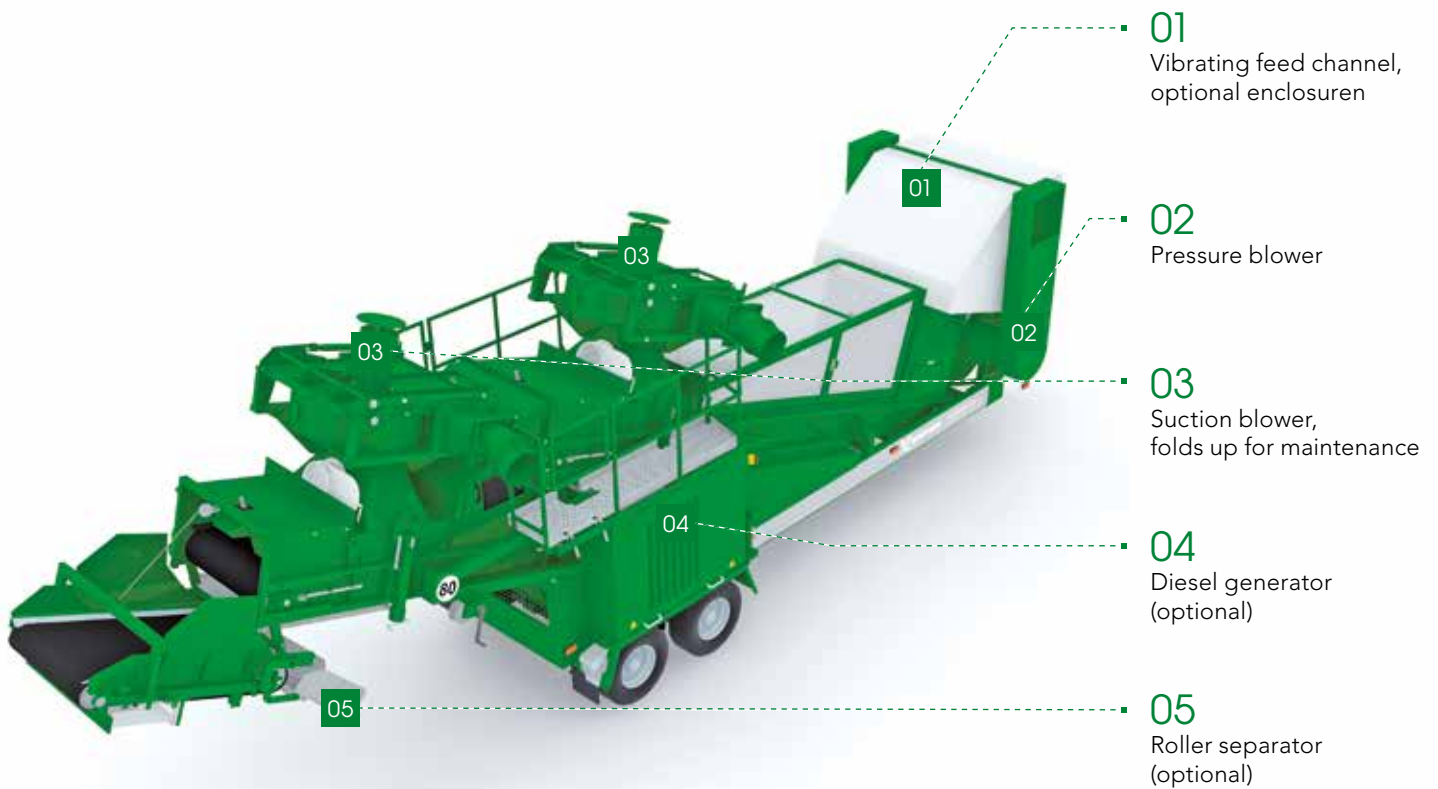

PATENTED SEPARATING SYSTEM

The pressure-suction system gives extremely effective removal of light materials from screen overflow. In the first step, the pressure blower separates the material. The light materials settle onto the remaining fraction. In the second step, the light materials are pulled away by a suction blower.



EXACT CONFIGURATION FOR THE TASK

The wide feed chute permits a 1200 mm wide screener conveyor and a loading height of 1950 to 2250 mm. Separation can be precisely adjusted for the material by means of blower speed, blower interval and air flaps.



WITH OPTIONS FOR CLEANING

The Hurrikan really cleans up with the optional magnetic drum and roller separator - round, heavy objects (mostly rocks) roll down an adjustable-slope conveyor to a chute and away.

TECHNICAL SPECIFICATIONS

HURRIKAN/S

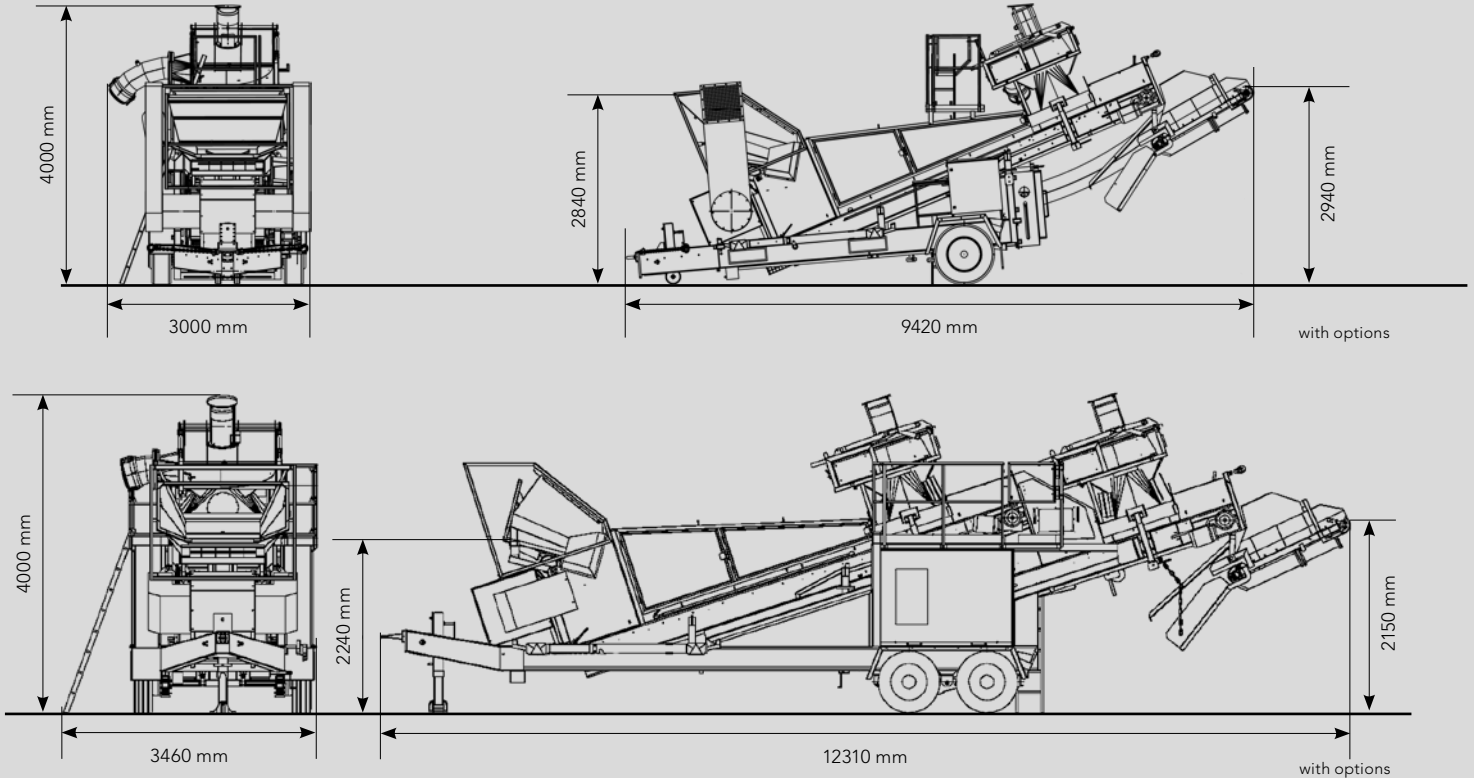

	HURRIKAN	HURRIKAN S
Drive		
Connection power (kW):	28	44
Diesel generator (kVA):	48	60
Material feed - feed conveyor		
Loading area width (mm):	1600	1600
Loading height (mm):	Adjustable from 1950 to 2250	Adjustable from 1950 to 2250
Clean fraction discharge		
Design:	Ribbed belt	Ribbed belt
Loading height (mm):	2900	2600
Dimensions L x W x H (mm)		
Transport dimensions central-axle-trailer:	8300 x 2550 x 4000	11000 x 2550 x 4000
Working dimensions central-axle-trailer	8130/9420* x 3000 x 4100 (*incl. roller separator)	11000/12310* x 3460 x 4000 (*incl. roller separator)
Total permissible weight (t):	6.5	10.0
Throughput (depending on material)		
Throughput (m³/h):	up to 40	up to 60
Hurrikan options		

Diesel generator, magnet drum, roller separator, frequency-converter for suction blower, special suction channels, enclosure for vibrating feeder and much more



249 Union Street
 Westfield, MA 01085
www.SimplicityNE.com
 800.553.6190